

18 Frame Block-Style 10K - Triplex Positive Displacement Plunger Pump

Model 1810

FEATURES

Superior Design

- Triplex plunger design provides smoother liquid flow.
- V-Packings and Lo-Pressure Seals are completely lubricated and cooled by the liquid being pumped.
- Low upswept volume maximizes volumetric efficiency.
- Oil bath crankcase assures optimum lubrication.
- Close tolerance concentricity of the ceramic plunger offers perfect alignment and maximizes seal life.

Quality Materials

- Precision stainless steel seat and ceramic ball provides true sphericity and long life.
- Block-style, stainless steel manifolds for strength and corrosion resistance.
- Special concentric, high-density, polished, solid ceramic plungers provide a true wear surface and extended seal life.
- Special UHMV supported V-Packings for high pressure stability and extended life.
- Die cast aluminum crankcase provides high strength, minimum weight and precision tolerance control.
- Chrome-moly crankshaft gives unmatched strength and surface hardness.
- Oversized crankshaft bearings with greater loading capacity mean longer bearing life.

Easy Maintenance

- Wet-end is easily serviced without entering crankcase, requiring less time and effort.
- Preset packings mean no packing adjustment is necessary, reducing maintenance costs.

SPECIFICATIONS

	U.S. Measure	Metric Measure
Flow.....	3.0 GPM	(11.4 L/M)
Pressure Range.....	100 to 10,000 PSI	(7 to 689 Bar)
Inlet Pressure Range.....	Flooded to 60 PSI	(Flooded to +4 Bar)
RPM	1500 RPM	(1500 RPM)
Bore.....	0.433"	(11 mm)
Stroke.....	1.181"	(30 mm)
Crankcase Capacity	42 oz.	(1.26 L)
Maximum Liquid Temperature	160°F	(71°C)
Above 130F call CAT PUMPS for inlet conditions and elastomer recommendations.		
Inlet Ports (2)	1/2" NPTF	(1/2" NPTF)
Discharge Ports (3)	3/8" FMP*	(3/8" FMP*)
Pulley Mounting	Either Side	(Either Side)
Shaft Diameter	1.181"	(30 mm)
Weight.....	60 lbs.	(27.3 kg)
Dimensions	19.53 x 12.99 x 6.44" (496 x 330 x 163.5 mm)	

*Autoclave Engineering Medium Pressure.

ELECTRIC HORSEPOWER REQUIREMENTS

FLOW		PRESSURE			RPM
		PSI 5000	PSI 7500	PSI 10,000	
U.S. GPM	L/M	BAR 345	BAR 517	BAR 689	
3.0	11.4	10.3	15.4	20.5	1500
2.0	7.6	6.8	10.3	13.7	1000
1.0	3.8	3.4	5.1	6.8	500

DETERMINING THE PUMP R.P.M. $\frac{\text{Rated G.P.M.}}{\text{Rated R.P.M.}}$ = $\frac{\text{"Desired" G.P.M.}}{\text{"Desired" R.P.M.}}$

DETERMINING THE REQUIRED H.P. $\frac{\text{GPM x PSI}}{1460}$ = Electric Brake H. P. Required

DETERMINING MOTOR PULLEY SIZE $\frac{\text{Motor Pulley O.D.}}{\text{Pump R.P.M.}}$ = $\frac{\text{Pump Pulley O.D.}}{\text{Motor R.P.M.}}$

See complete Drive Packages [Incls: Pulleys, Belts, Hubs, Key] Tech Bulletin 003.
Refer to pump **Service Manual** for repair procedure, additional technical information and **pump warranty**.

⚠ WARNING

All systems require both a primary pressure regulating device (i.e., regulator, unloader) and a secondary pressure safety relief device (i.e., pop-off valve, safety valve). Failure to install such relief devices could result in personal injury or damage to the pump or to system components. CAT PUMPS does not assume any liability or responsibility for the operation of a customer's high pressure system.

"Customer confidence is our greatest asset"

PARTS LIST

ITEM	P/N	MATL	DESCRIPTION	QTY
2	30067	STL	Key (M8x7.5x25)	1
5	92538	S	Screw, HHC Sems (M6x16)	8
8	43496	AL	Cover, Bearing	2
9	815281	FBR	Split Shim, Bearing Cover, 2 Pc.	2
	814800	S	Split Shim, Bearing Cover, 2 Pc.	2
10	11340	NBR	O-Ring, Bearing Case - 70D	2
11	43495	NBR	Seal, Oil, Crankshaft - 70D	2
15	39060	STL	Bearing, Roller	2
20	48600	TNM	Rod Assy, Connecting	3
25	43494	FCM	Crankshaft - Dual End	1
31	828710	—	Protector, Oil Cap w/Foam Gasket	1
32	43211	ABS	Cap, Oil Filler	1
33	14177	NBR	O-Ring, Filler Cap - 70D	1
37	92241	—	Gauge, Oil, Bubble w/Gasket - 80D	1
38	44428	NBR	Gasket, Flat, Oil Gauge - 80D	1
40	92542	S	Screw, HHC Sems (M6x20)	4
48	25625	STCP	Plug, Drain (1/4"x19BSP)	1
49	23170	NBR	O-Ring, Drain Plug - 70D	1
50	43491	AL	Cover, Rear	1
51	44834	NBR	O-Ring, Rear Cover - 70D	1
53	115471	AL	Crankcase (Incls: 54)	1
54	27488	S	Pin, Guide	2
64	43507	CM	Pin, Crosshead	3
65	48892	SSHB	Rod, Plunger, Short	3
69	126592	STCP R	Washer, Seal	3
70	43500	NBR	Seal, Oil, Crankcase - 80D	3
75	43506	S	Slinger, Barrier	3
90	76595	CC	Assembly, Plunger, M11 w/SS Holder	3
95	31585	STL	Stud, Plunger (M6 x 20)	3
100	43509	POP	Retainer, Rear Seal	3
106	76110	PTFE	Seal, LPS w/SS-Spg	3
107	31590	D	Spacer, LPS	3
110	76840	S	Block, Housing	1
116	31545	S	Washer, Flat (M10)	4
117	31695	S	Screw, HSH (M10 x 100)	4
121	31565	PTFE	Ring, Cylinder Sealing	9
122	31485	NBR	O-Ring, Front Cylinder - 70D	3
123	31475	NBR	O-Ring, Rear Cylinder - 70D	3
124	76490	S	Cylinder	3
127	76310	UHMW/BZ	Assembly, V-Packing w/Cylinder Support	3
134	76350	S	Valve, Inlet	3
135	76115	S	Retainer, Inlet Spring	3
136	31575	S	Spring, Inlet Valve	3
164	76510	S	Seat, Ball Assembly w/Ceramic Ball	3
185	76880	S	Manifold, Inlet/Discharge, Block-Style	1
188	31692	S	Screw, HSH (M10 x 140)	8
250	30764	NY	Protector, Shaft w/Two Screws	1
	30764S	NY	Protector, Shaft w/Two SS Screws	1
255	30264	STZP	Mount, Direct	1
260	30613	STZP R	Mount, Rail Assy	1
	990550	STZP R	Mount, Rail (Required on Diesel/Gas)	1
269	30206	F	Pulley (10") AB [See Drive Packages, Tech Bulletin 003]	1
274	30059	STL	Hub, "H" (M30) (Keyway M8) [See Drive Packages, Tech Bulletin 003]	1
283	34334	—	Kit, Oil Drain (3/8" x 24")	1
299	992810	S	Head, Complete, w/Plungers	1
300	76810	NBR*	Kit, Seal (Incls: 106,107, 121,122, 123, 127)	1
310	76820	NBR	Kit, Valve (Incls: 121, 122, 123, 134, 136, 164)	1
350	30696	STZP	Plier, Reverse	1
352	44050	STZP	Tool, Oil Gauge Removal	1
400	9910	SS	Assembly, Rupture Disc (Relief Valve) (Includes 3 discs)	1
—	76010	SS	Rupture Disc, 15K	1
—	76055	SS	Plug, Assy, 3/8" MP, 20K	1
—	76065	SS	Nipple Assy, 3/8" MP, 20K	1
—	76040	SS	Adapter, 3/8" MP x 3/8" NPTF, 10K	1
—	76041	SS	Adapter, 3/8" MPM x 1/2" NPTF, 10K	1
—	76047	SS	Tee, 3/8" MP, 20K	1
—	6107	—	Oil, Bottle (21 oz.) ISO-68 Hydraulic (Fill to specified crankcase capacity prior to start-up)	2
—	6119	—	Lubricant, Antiseize (1 oz.)	1

Italics are optional items. R Components comply with RoHS Directive. *Review individual parts in each kit for material code identification.
See Tech Bulletins 002, 003, 024, 035, 036, 043, 074, 077, 083 and 095 for additional information.

MATERIAL CODES (Not Part of Part Number): ABS=ABS Plastic AL=Aluminum CC=Ceramic CM=Chrome-Moly D=Delryn F=Cast Iron FBR=Fiber
FCM=Forged Chrome-Moly NBR=Medium Nitrile (Buna-N) NY=Nylon POP=Polypropylene PTFE=Pure Polytetrafluoroethylene S=304SS
SSHB=316SS w/High Strength Brass STCP=Steel/Chrome Plated STL=Steel STZP=Steel/Zinc Plated
TNM=Special High Strength UHMW=Ultra High Molecular Weight Polyethylene

EXPLODED VIEW

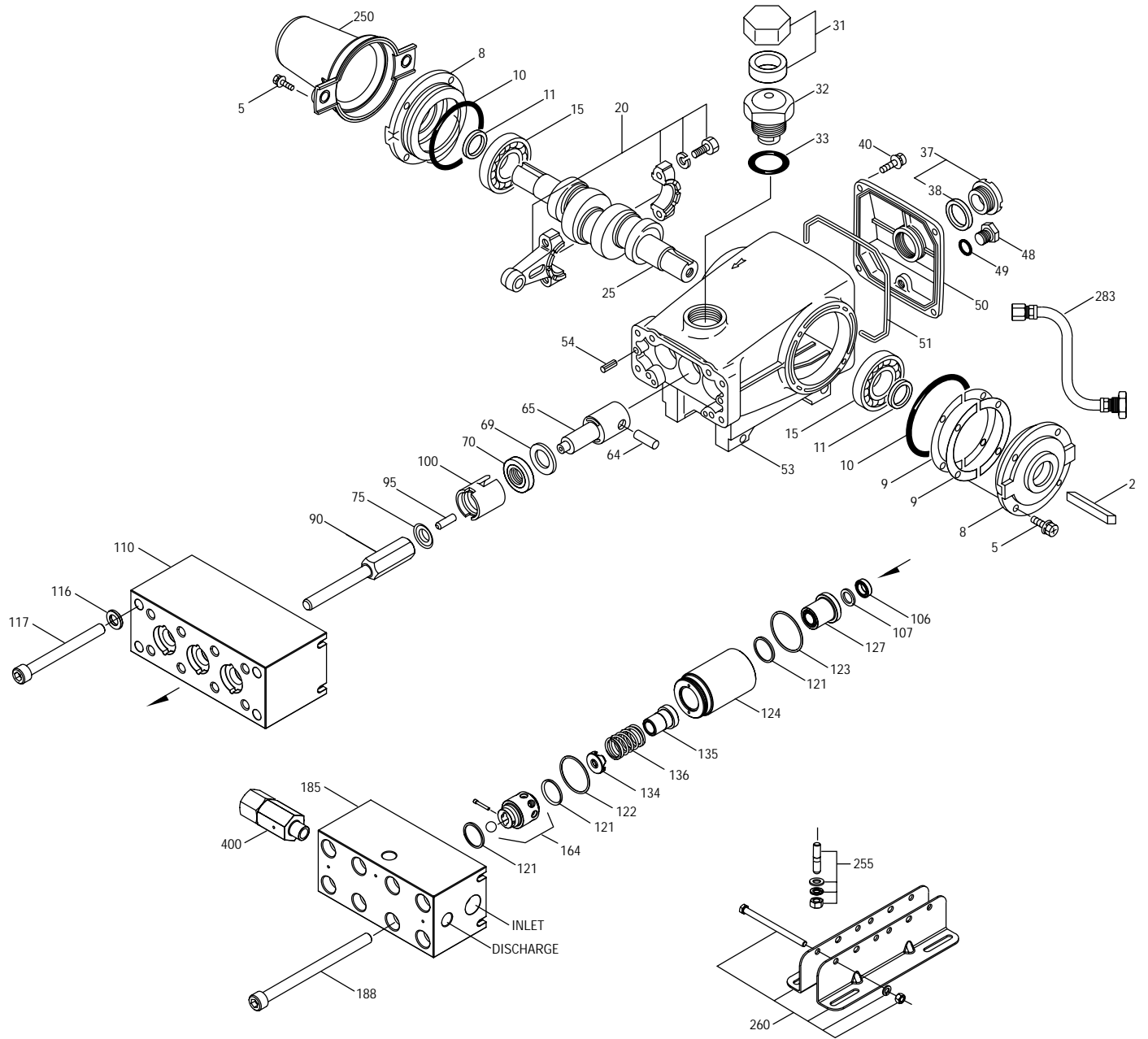

Model
1810
January 2009

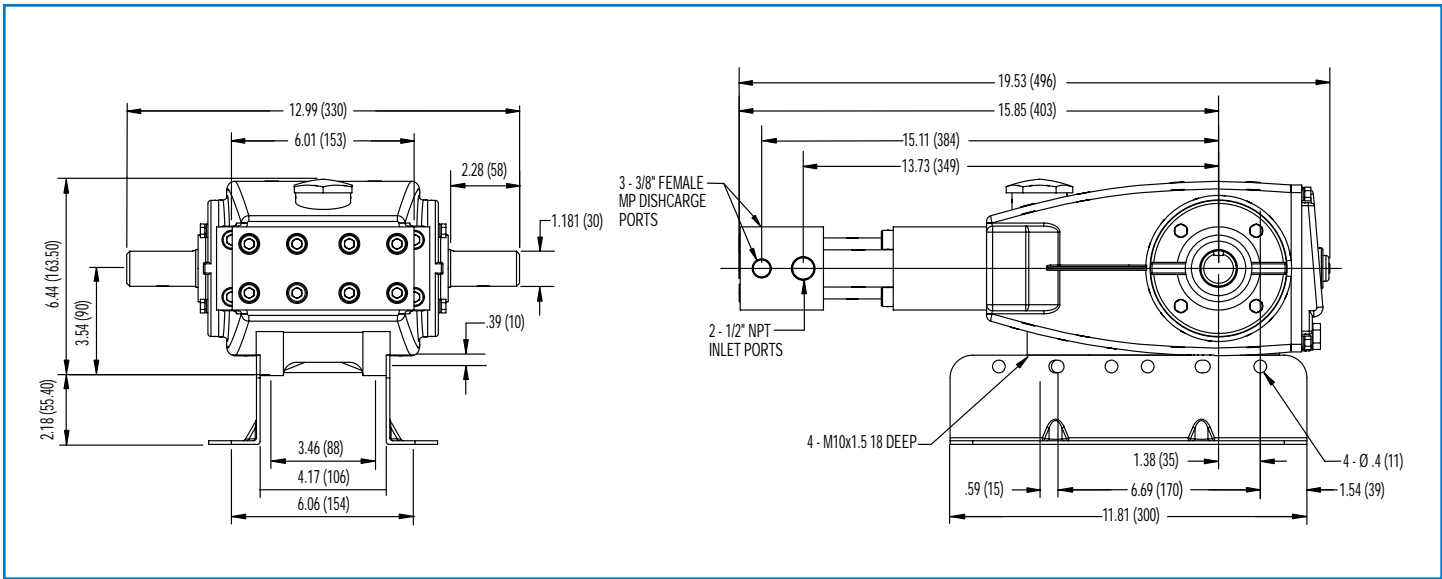

Model 1810

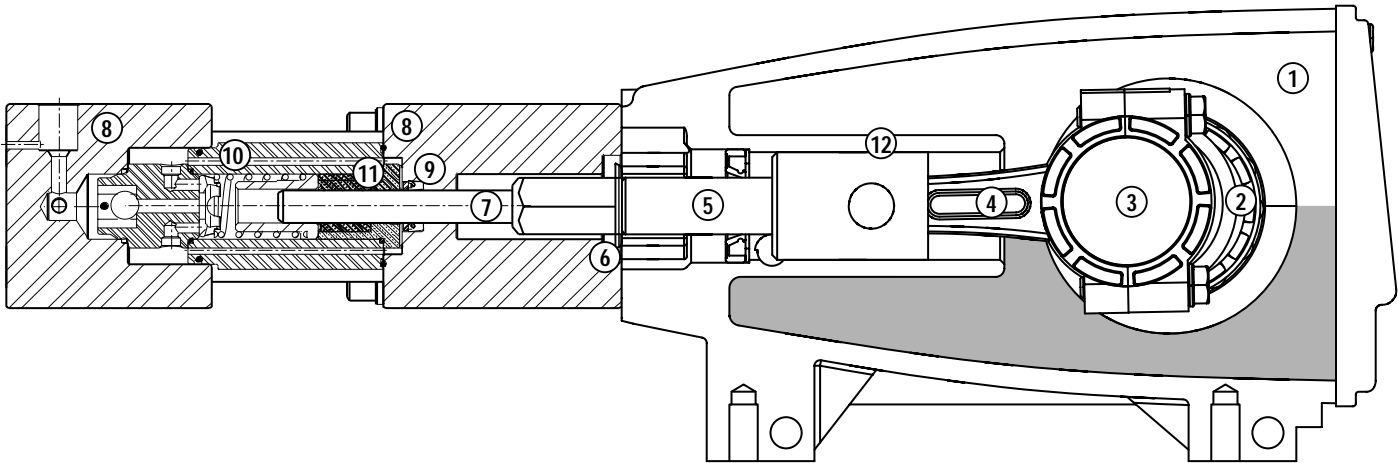

- 1 Die cast aluminum **crankcase** means high strength, lightweight, and excellent tolerance control.
- 2 Oversized crankshaft **bearings** provide extended bearing life and pump performance.
- 3 Chrome-moly **crankshaft** provides unmatched strength and surface hardness for long life.
- 4 Matched oversized TNM **connecting rods** noted for superior tensile strength and bearing quality.
- 5 Special stainless steel high strength **plunger rods** for high load bearing and longevity.
- 6 The stainless steel **slinger** provides back-up protection for the crankcase seal, keeping pumped liquids out of the crankcase.
- 7 Special concentric, high-density, polished, solid ceramic **plungers** provide a true wear surface and extended seal life.
- 8 **Manifolds** are a high tensile strength stainless steel for long term, continuous duty and corrosion resistance.
- 9 100% wet **seal** design adds to service life by allowing pumped liquids to cool and lubricate on both sides.
- 10 Precision stainless steel **seat and ceramic ball** provide true sphericity and extended life.
- 11 Special UHMW supported **V-Packings** for high pressure stability and extended life.
- 12 **Crossheads** are 360° supported for uncompromising alignment.

Products described hereon are covered by one or more of the following U.S. patents 3558244, 3652188, 3809508, 3920356, 3930756 and 5035580

World Headquarters
CAT PUMPS
 1681 - 94th Lane N.E. Minneapolis, MN 55449-4324
 Phone (763) 780-5440 — FAX (763) 780-2958
 e-mail: techsupport@catpumps.com
 www.catpumps.com

International Inquiries
 FAX (763) 785-4329
 e-mail: intlsales@catpumps.com



CAT PUMPS (U.K.) LTD.
 1 Fleet Business Park, Sandy Lane, Church Crookham
 FLEET, Hampshire, GU52 8BF, England
 Phone Fleet 44 1252-622031 — Fax 44 1252-626655
 e-mail: sales@catpumps.co.uk www.catpumps.co.uk

N.V. CAT PUMPS INTERNATIONAL S.A.
 Heiveldekens 6A, B-2550 Kontich, Belgium
 Phone 32-3-450.71.50 — Fax 32-3-450.71.51
 e-mail: cpi@catpumps.be www.catpumps.be

CAT PUMPS DEUTSCHLAND GmbH
 Buchwiese 2, D-65510 Idstein, Germany
 Phone 49 6126-9303 0 — Fax 49 6126-9303 33
 e-mail: catpumps@t-online.de www.catpumps.de