

Fawcett Christie Hydraulics Ltd
 Glendale Avenue, Sandycroft Industrial Estate,
 Sandycroft, Deeside, Flintshire, CH5 2QP. UK
 Tel: +44 (0) 1244 535515 Fax: +44 (0) 1244 533002
 Email: sales@fch.co.uk www.fch.co.uk

207, 310, 345 & 420
 bar



Specification

Shell

Oil Service - seamless shell, designed and manufactured to PED 97/23/EEC and CE marked. Material - Chromium-molybdenum steel. Working pressure 207, 310, 345 and 420 bar. Water service as above with shell interior epoxy resin lined.

Label

With assembly specification and installation details

Witness hydro-pneumatic pressure tests

These are carried out on complete accumulators and can be undertaken for a specific inspection authority and/or customer requirement as an optional extra.

Material Certification

Available on request for all major pressure loaded parts to EN 10204 3.1

Finish

One coat primer paint as standard. Special paints available.

Bladder

Totally enclosed construction with an extensive range of elastomers available. See Bladder information for further details.

Fluid Port Assembly

Integral high-flow port and poppet valve assembly with an anti-extrusion ring. For options see overleaf.

Safety

All gas-loaded accumulators are pressurised vessels and it is recommended that safety consideration be given to the application in which they are used. A relief valve should always be fitted to the hydraulic system with the option of a burst disc to protect the accumulator. If there is a fire risk in the vicinity of the accumulator, then a fusible/eutectic plug should be fitted. See Installation and Servicing data sheet for information regarding installation of accumulators.

Accessories

A complete range of accumulator accessories are available from Fawcett Christie Hydraulics.

Spare Parts

Available on request.



A	Bladder Kit comprising:
D	Bladder assembly
D1	Bladder
D2	Gas valve assembly
D3	Locknut
D4	Protective cap
D5	'O' ring stem
E	Anti extrusion ring assembly
E1	Anti extrusion ring
E2	'O' ring fluid port
E3	Bonded seal
E4	Back-up ring
B	Fluid port assembly comprising
B1	Fluid port body
B2	Spring
B3	Poppet valve
B4	Collett
B5	Piston
B6	Flanged washer
B7	Locking ring
B8	Bleed adaptor
B9	Bleed valve
C	Shell assembly comprising:
C1	Shell
C2	Label
C3	Label warning

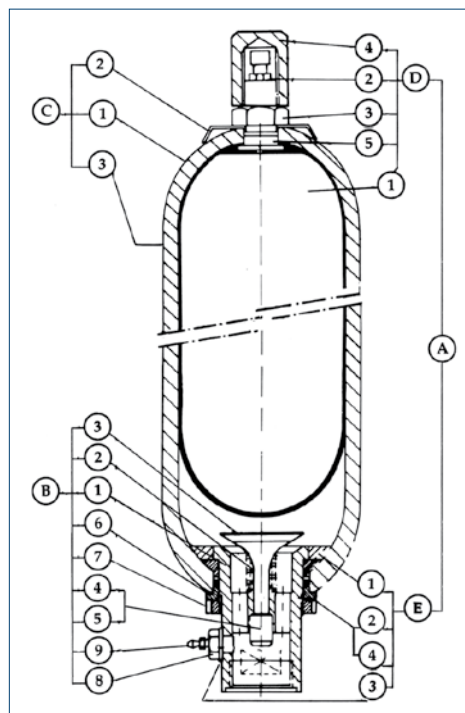

Note: Models 1/54 litres detailed above. Models 0.6 litres and below have Gas Valve assembly integral with bladder stem without protective cap fitted.

Model Numbers for Standard Bladder Accumulators

54 0 0A 00 20 1

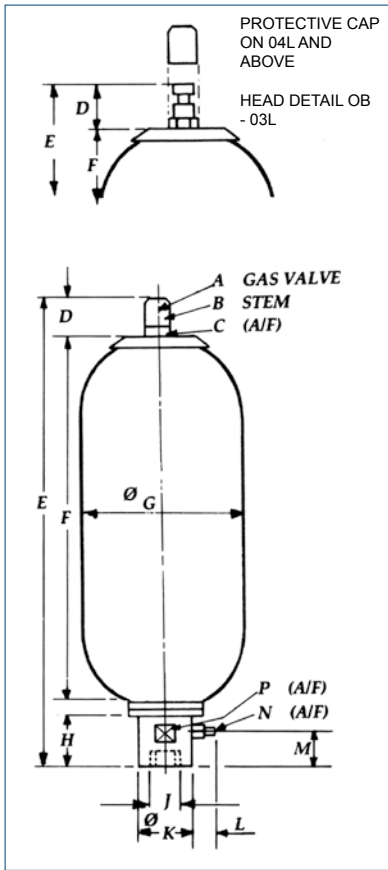

Nominal Volume - Litres

Bladder Material

- 0 = Nitrile Standard
- 1 = Butyl
- 2 = Low Temperature Nitrile
- 3 = Low permeability
- 6 = Viton
- 8 = High Temperature Nitrile

Bladder Stem/ Gas Valve

- 0B-0F
- OA = 5/8" UNF/1/4" BSPM
- 9A = 5/8" UNF/302-32
- SA = as OA but corrosive service

- 01-37L
- 7/8" UNF/1/4" BSPM
- 7/8" UNF/302-32
- 54L
- M50 x 1.5 / 1.4" BSPM
- 7/8" UNF / 302-32

Shell and Fluid Port Options

- 00 = Oil Service
- 02 = Low/medium corrosive service
- 03 = British coal industry spec. water service
- 04 = British coal industry oil service
- 13 = NPT fluid port - oil service

- 14 = NPT fluid port - Low/medium corrosive service
- W6 = Stainless steel externals, unlined shell
- Note: for other assembly options contact Head Office
- DN - SAE 6000 flange nipple

Maximum Working Pressure

- 20 = 207 bar
- 34 = 345 bar
- 42 = 420 bar
- 31 = 310 bar
- 35 = 350 bar

Design Standard/ Authority Approval

- 1 = Lloyds/CE

Nominal Capacity Litres	Effective Gas vol. Litres	Work press. bar	Max Flow Rate lt/min	Weight Dry Kilo	Dimensions in mm unless stated otherwise and subject to manufacturer's tolerances													
					A Inches	B Inches	C	D	E	F	G	H	J Inches	K	L	M	N	P
OB	0.16	345	27	2.00	1/4 BSP	5/8 UNF	24	40	292	205	56	36	3/4 BSPM	26	-	-	-	23
OF	0.60	345	109	2.70	1/4 BSP	5/8 UNF	24	40	266	175	92	37	3/4 BSPF	35	-	-	-	32
01C	1.15	350	109	5.70	1/4 BSP	7/8 UNF	28	78	330	200	116	37	3/4 BSPF	35	-	-	-	32
03C	2.5	350	215	10.00	1/4 BSP	7/8 UNF	28	78	565	402	116	49	1 1/4 BSPF	52	5	40	15	50
04	3.8	207	477	15.20	1/4 BSP	7/8 UNF	33	78	455	289	169	74	1 1/4 BSPF	60	36	39	9	55
04	3.8	345	477	15.20	1/4 BSP	7/8 UNF	33	78	455	289	169	74	1 1/4 BSPF	60	36	39	9	55
10	9.4	207	749	30.00	1/4 BSP	7/8 UNF	33	78	575	407	221	70	2 BSPF	76	36	46	9	69
10	9.4	310	749	30.00	1/4 BSP	7/8 UNF	33	78	575	407	221	70	2 BSPF	76	36	46	9	69
10	9.4	345	749	30.00	1/4 BSP	7/8 UNF	33	78	575	407	221	70	2 BSPF	76	36	46	9	69
10	9.4	420	749	34.00	1/4 BSP	7/8 UNF	33	78	575	407	228	70	2 BSPF	76	36	46	9	69
20	18.8	207	749	46.00	1/4 BSP	7/8 UNF	33	78	886	718	221	70	2 BSPF	76	36	46	9	69
20	18.8	310	749	46.00	1/4 BSP	7/8 UNF	33	78	886	718	221	70	2 BSPF	76	36	46	9	69
20	18.8	345	749	46.00	1/4 BSP	7/8 UNF	33	78	886	718	221	70	2 BSPF	76	36	46	9	69
20	18.8	420	749	54.00	1/4 BSP	7/8 UNF	33	78	886	718	228	70	2 BSPF	76	36	46	9	69
28	25.8	207	749	61.00	1/4 BSP	7/8 UNF	33	78	1158	990	221	70	2 BSPF	76	36	46	9	69
28	25.8	310	749	61.00	1/4 BSP	7/8 UNF	33	78	1158	990	221	70	2 BSPF	76	36	46	9	69
28	25.8	345	749	61.00	1/4 BSP	7/8 UNF	33	78	1158	990	221	70	2 BSPF	76	36	46	9	69
28	25.8	420	749	70.00	1/4 BSP	7/8 UNF	33	78	1158	990	228	70	2 BSPF	76	36	46	9	69
37	35.2	207	749	74.00	1/4 BSP	7/8 UNF	33	78	1407	1239	221	70	2 BSPF	76	36	46	9	69
37	35.2	310	749	74.00	1/4 BSP	7/8 UNF	33	78	1407	1239	221	70	2 BSPF	76	36	46	9	69
37	35.2	345	749	74.00	1/4 BSP	7/8 UNF	33	78	1407	1239	221	70	2 BSPF	76	36	46	9	69
37	35.2	420	749	86.00	1/4 BSP	7/8 UNF	33	78	1407	1239	228	70	2 BSPF	76	36	46	9	69
54	49.2	207	749	102.00	1/4 BSP	M50x 1.5	69	66	1922	1766	221	70	2 BSPF	76	36	46	9	69
54	49.2	310	749	102.00	1/4 BSP	M50x 1.5	69	66	1922	1766	221	70	2 BSPF	76	36	46	9	69
54	49.2	345	749	102.00	1/4 BSP	M50x 1.5	69	66	1922	1766	221	70	2 BSPF	76	36	46	9	69
54	49.2	420	749	119.00	1/4 BSP	M50x 1.5	69	66	1922	1766	228	70	2 BSPF	76	36	46	9	69